



THE AFTER MARKET SHEET



VOL. 60A, No.8A WWW.SVSM.ORG MAY 2026

A Publication of the SVSM Chapter of International Plastic Modeler's Society, USA

ACTUAL COVERAGE !



OKAY, while I await the minutes for the incredible May meeting, you can feast on some news for each and every one of these pictured subjects inside, starting at page 3.



Editor's MisBehaviors – this month's editor, Mick Burton



(shameless plug: www.mickbmodeler.com)

“ **EDITOR SEES HOW WE TAKE OUR CRAP SERIOUSLY** ”

I had to slip this in here, with all sort of work ahead but timing is everything. SO read on, this was from just last weekend!

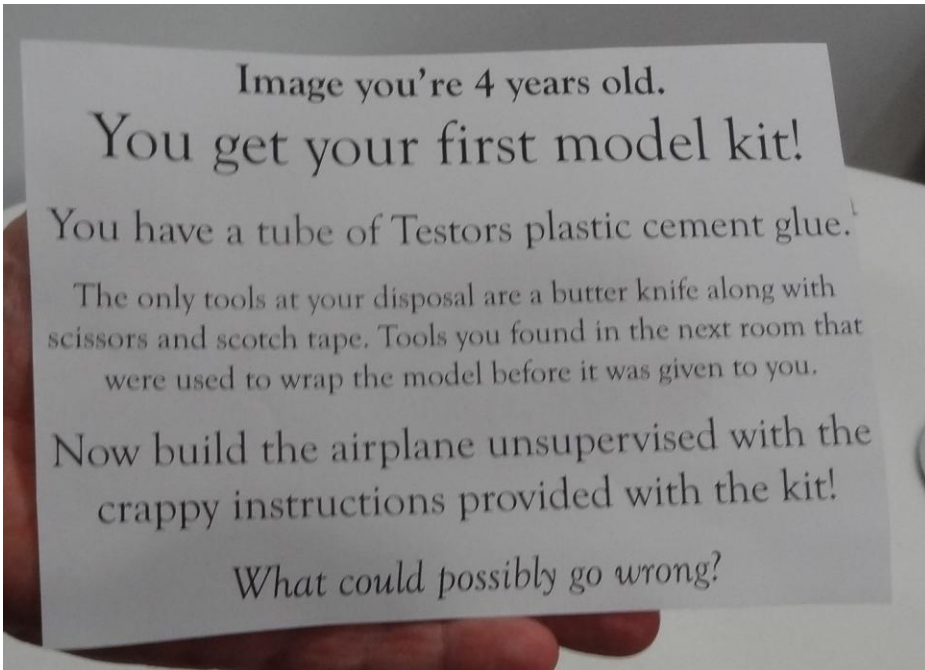

**CONGRATULATIONS HUBERT CHAN
THANK YOU ERNIE and FSM Crew!**

Because I had highlighted my delight in the last issue's editorial as to how RC Ernie Gee was doing this masterful wicked competition for the big Memorial Day Weekend FSM & Castle AFB Contest/Show, couldn't leave it.

Here is a sample of the turnout for how hard core and hilariously “Crappy Model” category competition went. Winner got First, President's Award & Crappiest Model He won with an Out Of The Box entry, deservedly, tho my favorite was the Xmas Day Sabre Dog with a grand story! **-mb**

TABLE OF CONTENTS MAY 2026 AFTERMARKET

- 1) **COVERAGE : AN ACCOUNT of APRIL WCME, MODEL ARTICLE by KENT M, PREVIEW Oct Club Contest**
- 2) **MORE CONFUSED SCRAMBLE BY EDITOR along with PERHAPS USEFUL TABLE OF CONTENTS**
- 3) **A Look Over The WINE COUNTRY MODEL EXPO of 2026 APRIL opener event of Region 9** (runs to 9)
- 10) **EVENTS CALENDAR**
- 11) **EGG-ZAMINING a FEW VARIATIONS then FOCUS on EGGCELLENT Model Diversion by Kent McClure**
- 16) **BREAKING NEWS for OCTOBER SKY 2026 Club Contest SVSM Member Mark Balderrama Sponsoring**
- 17) **OFFICIAL FLYER (two pages) San Joaquin Valley Scale Modelers CONTEST AUGUST 2026 Go TOMCATS**
- 19) **OFFICIAL FLYER FOR WONDERCON IV in OXNARD on AUGUST 30 2026**
- 20) **OFFICIAL FLYER FOR 2026 RENO HIGH ROLLERS Red White & Blue CLASSIC SEPTEMBER 2026**
- 21) **OFFICIAL FLYER FOR IPMS ORANGE COUNTY ORANGECON 2026 EVENT OCTOBER 11 2026**
- 22) **OFFICIAL FLYER AVG Desert Classic # 28 OCTOBER 17 2026**
- 23) **REMINDER JULY 2026 SVSM Club Contest “RIDE THE WAVE”**
- 23) **REMINDER SVSM JUNE 2026 MEETING 3RD FRIDAY USUAL TIME REGULAR LOCALE** no fooling!

Now Showing : APRIL 2026 Wine Country Model Expo



New Year Region Nine Launch Vehicle !

Photos/Text : Mick Burton

*April 11 2026 saw us returning to a familiar well loved venue years later in a new way with Wine Country Modelers of Sonoma County leading the charge. Above shot is early in day several open spaces soon filled !
One difference from "the usual shows in R-9" is illustrated below, you entered your items all in one sitting...*

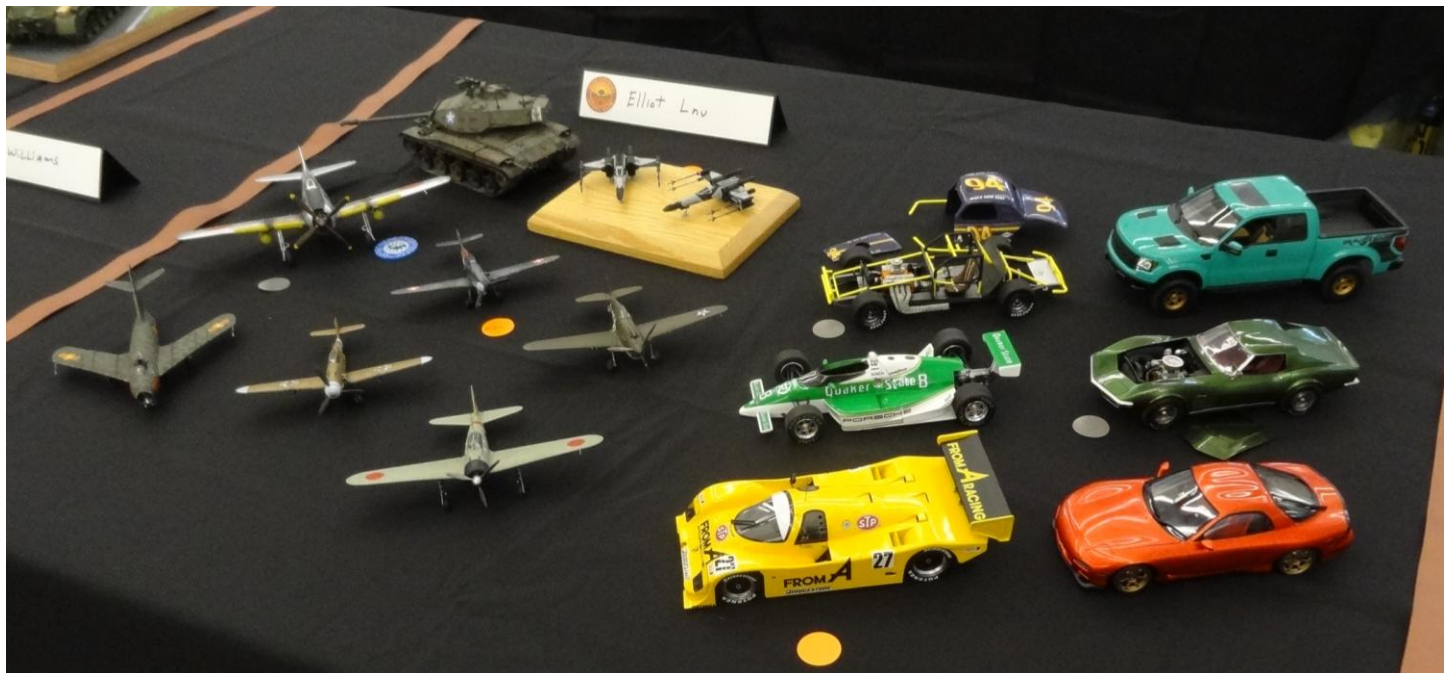



Again, these pictures were taken by Editor early in the show day, after he got his bearings upon arrival.



So again, although already a prettu good bunch of models were on the tables from a healthy number of modeler entrants, more yet were coming along to take on all the offered display space. As well then to enjoy getting a further improved version of their Gold, Silver or Bronze judging entries system which was first tried out two years ago by the club hosts. That "Evolution of Modelling" theme event at the Rohnert Park Community Center saw this bold move by a veteran R-9 club have a pleasing record for them in turnout. That it also gave impetus here. With "EoM", they had learned a lot about what worked or what needed improvement for next step which saw them return to Petaluma Community Center, an alma mater of very good contests in past.

Besides putting together a very good in depth online presence well enough ahead of time so you could learn what the details of what the "G S B" judging and awarding process was, so you would be better prepared and less in a position to let any disparaging comments be your guide so maybe no show, they also had offered all an "early preregistration" too !

Okay now here you can mayhaps see how much space in the rear was filled in and also here now is the third and final residence that fit all his entries, my good friend and IPMS Monterey Bay hero Ramon Lomeli, his models are in between the red stripe at green AN-2 Colt and the red stripe on right near flying B-17...



Ramon had to try out two other placements before getting this one provided which was a huge help and great to see on display. Bob Phillips no slouch either, coming from Stockton to show these lovelies below. Go SJVSM !





Dennis Meyers had another display that not only well captured his expertise in scale modelling right there on the front line, it also well illustrated what I find a benefit for achieving enlivening the viewing public who may not even be modelers, competitive or otherwise. Here on one section of table, you have several scales of Jet a/c, Prop a/c, military vehicles of several types, figures both full and bust format. One gets direct information this modeler has a variety of interests, there are some nice models of sometimes familiar sometimes not, subjects.

Next to him, I espied a personal rather obscure favorite of mine which I know our current SVSM President Eugenie shares a fondness for. Her rendition of this 1/72nd Yakovlev Yak-6 still the best one I have seen, still... Have to include this shot as an admiring nod to this builder for even doing it and an applause again to Eugenie



Alright, now if you didn't already know, yes they were awarding Gold, Silver, Bronze to individual models within a single entrants items as the curated Judging teams saw fit to as per their outlined criteria, which if you have been through it you will get the direct message these ARE NOT Participation trophies and you may not even get one even if you have entered what you think are an abundance of your best "winning class" models



However, WCME did again offer several Special Awards such as we are used to at "usual contests" and I happened to have sponsored one myself. Above is an example of one, won by a Fremont Hornet for his AEG.

Here is the great collection of motorwarks by NNL West guru Mike English, who won the Best Auto Subject I sponsored for this event. Yet I unfortunately didn't even get the T-shirt much less a picture of the bloody award



And in keeping with the WCME tradition, Special Awardees also got a bottle of wine for each one !



And to finally get this record straight, the Airfix Meteor F8 and Bandai Gundam here were trades to me for an Airfix Shackleton AEW and an Eduard 1/48th Special Edition B-17 (not shown). I also won the 1/16 Tiger seen here in big raffle. It's now part of the upcoming TC-18 raffle pool. Winning was fun, end results better.



All in all, the first big show of Region Nine 2026 event year went off well as it was premised, and had a plenty large and wide ranging attendance. My hopes that we see this event repeated in the future, to be sure, make it so

The above shot is an excellent model of a fine old character from the excellent old time Gojira (Godzilla) movie series, and is also perfect example of my face when I showed up at this well remembered event hall and found out as a long time customer, that sadly there were nearly no vendors there! I was used to finding the big contest room fitted with many tables along the edges while plenty of room for the models still, along with the entry hall I found out that it was a very limited by design layout this time, and harder on old folks like me, also almost no chairs to be found inside the big room too. While attendees dealt the limited seating and unexpected reduced set of vendors to add to our fun, I would like to offer my hopes that next Expo that more consideration for making a greater flexibility in both offering Vendor attendance and more guest seating. I know Petaluma locale can do it as plenty pictures on file to show it done. Also again, as customer and a show exec myself, bet likely be a boon.

THANK YOU WINE COUNTRY MODELERS FOR DOING THIS EVENT !!

UPCOMING EVENTS CALENDAR AS OF 05-30-26

Friday, June 12 2026

IPMS/ Fremont Hornets host their meeting at IRVINGTON COMMUNITY CENTER in Fremont

Friday, June 19 2026

IPMS/ Silicon Valley Scale Modelers meeting at MPD Community Room. **D-Day for Let Me Finish That For You**

Monday, June 29 2026 NEW

IPMS/ SV Scale Modelers OPEN BUILDFEST at **The PLEX, 800 Embedded Way, Northside Meet Room, San Jose.**

Friday, July 12 2026

IPMS/ Fremont Hornets host their meeting at IRVINGTON COMMUNITY CENTER in Fremont

Friday, July 19 2026

IPMS/ Silicon Valley Scale Modelers meeting at MPD Community Room. **Ride The Wave Club Contest**

Friday, August 12 2026

IPMS/ Fremont Hornets host their meeting at IRVINGTON COMMUNITY CENTER in Fremont

Friday, August 19 2026

IPMS/ Silicon Valley Scale Modelers meeting at MPD Community Room. **Guns of August Club Contest**

Saturday, August 29 2026

San Joaquin Valley Scale Modelers host their Contest at Stanislaus County Veterans Services, Modesto CA

Sunday, August 30 2026 NEW

IPMS/ One Oh Wonders Ventura County Scale Modelers host their WONDERCON IV in Oxnard

Friday, September 11 2026

IPMS/ Fremont Hornets host their meeting at IRVINGTON COMMUNITY CENTER in Fremont

Friday, September 18 2026

IPMS/ Silicon Valley Scale Modelers meeting at MPD Community Room. **Tracks 'n Track Club Contest**

Saturday, September 26 2026

IPMS/ Reno High Rollers host their 25th Classic at National Auto Museum, Reno NV Theme is "Red, White & Blue"

Friday, October 09 2026

IPMS/ Fremont Hornets host their meeting at IRVINGTON COMMUNITY CENTER in Fremont

Sunday, October 11 2026

IPMS/ Orange County Scale Modelers host their major event ORANGECON CONTEST & SHOW in Buena Park at the Double Tree Hilton. Theme is "AMERICAN SPIRIT"

Friday, October 16 2026

IPMS/ Silicon Valley Scale Modelers meeting at MPD Community Room. **October Sky Club Contest**

Saturday, October 17 2026

IPMS/ Antelope Valley Group host their DESERT CLASSIC #28 at Antelope Valley College cafeteria, confirmed Antelope Valley College, 3041 W Avenue K, Lancaster, CA Theme is "Feminine Phenomenons"

Saturday, November 14 2026

IPMS/ Fremont Hornets host their CONTEST & Show TriCity EIGHTEEN themed "TOP GUN" being held at the Fremont Elks Lodge #2121, 38991 Farwell Dr, Fremont CA

A “ JOOB*-alant ” Look at the Hughes Egg Beater

Photos/Text : Kent McClure

*JOOB = Just Out Of Box (*blame the Editor for that part*)

Another tongue-in-cheek review here. This time it's a Hasegawa kit, number 52196 – No.7 in the Egg Girls Collection.

Actually, it's the egg-plane rendition of a Hughes Model 300 helicopter done up as a police traffic helicopter.

And as an added bonus this kit comes with a 1/20th scale figure of an anime stylized policewoman.

If you are not familiar with the concept of “egg planes”, here's a brief tutorial. As the name implies, these are caricature kits of aviation subjects using the basic ovoid egg shape as its main characteristic.

Some aircraft seem to naturally fall into this category as the prototype of the kit subject “looks” like an egg. For example, the F-4 Phantom, the PBV Catalina, the MiG-15, the AC-119. Even the SR-71.

It's not too hard to “see” the basic egg shape in the real planes.

The first “egg” plane that I remember seeing was an F-4 Phantom. It was produced by a company called IPT Inc (Industrial Promotional Toys) back in 1975 (at least that is the copyright date on the box).

It was part of a line of kits called Eggocentrics.

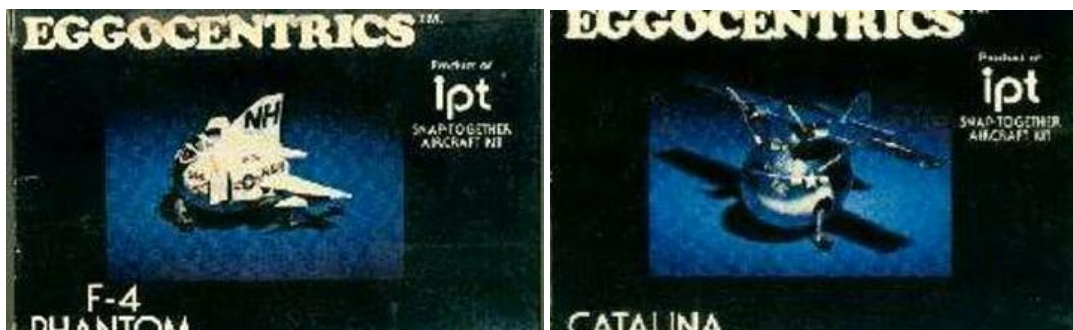

My first two egg kits – the F-4 and the PBV

There were 6 kits in the series - the F-4, A-7, DC-10, Boeing 747, Boeing 727 and the PBV – and were “Snap Together” kits. I had the F-4 and the PBV. I don't remember when I picked up the kits, but I think that they faded into obscurity rather quickly.

Flash forward to 1978 and Hasegawa brought out their Tamago Plane series, and Hasegawa has been going strong producing “egg” planes since then. (*author's note: Tomago is the Japanese word for egg*).

In 2018, Hasegawa began pairing some of their “egg” planes with 1/20th scale resin anime girl figures as “Egg Girls”.

Since then other companies have joined the “egg” bandwagon including Meng, Fujimi and AFV Club, and they have branched out to include ships and armor subjects. But those subjects seem to only marginally fit the “egg” theme.

However, Reskits have started producing aftermarket cockpit sets for some of the models. And they are not too bad, mainly hacking out the kit's old “cockpit” and dropping in the NEW Reskit one.

Now on to the subject matter at hand – the Hughes Model 300.



Hasegawa's Amy McDonnell and the Hughes Model 300 (kit #52196)

This helicopter (for that fact any “bubbled style” helicopter) is a perfect choice for the basis of an egg kit. Why?

Because, seriously, it looks like an egg!

The Hasegawa kit has 22 parts on 2 white sprues and 2 clear parts on a single sprue. There are no obvious ejector pin or sink marks on the white pieces.

The clear parts are okay and luckily are separated along the vertical plane (left and right halves). Unfortunately, they were not bagged separately from the other parts. But, luckily, the “glass” appears not to have any scratches on it.

The sprue gates are thinnish, and there was no flash on the model to speak of.

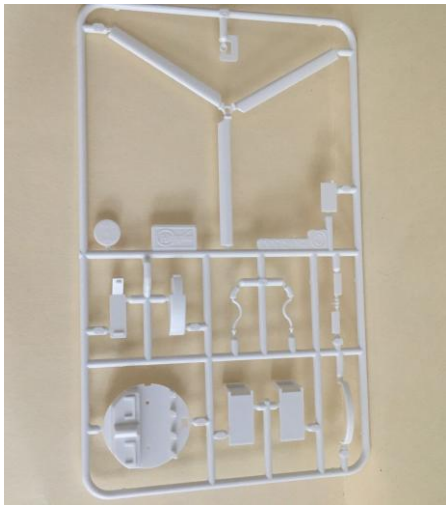

The Sprues

The figure of “Amy”, the policewoman, was bagged separately and consisted of 9 pieces of flesh colored resin.

The figure appeared to be cleanly cast with no visible air bubbles, but it does have some flash that needs to be cleaned up.



Figure of Amy

The instructions are on a 6 7/8" by 18 3/4" sheet of paper, quad folded. The outside of the instructions is the painting guide for the helicopter and Amy in grey scale, while the inside is the 4-step assembly guide for the helicopter and 1 step assembly guide for Amy.

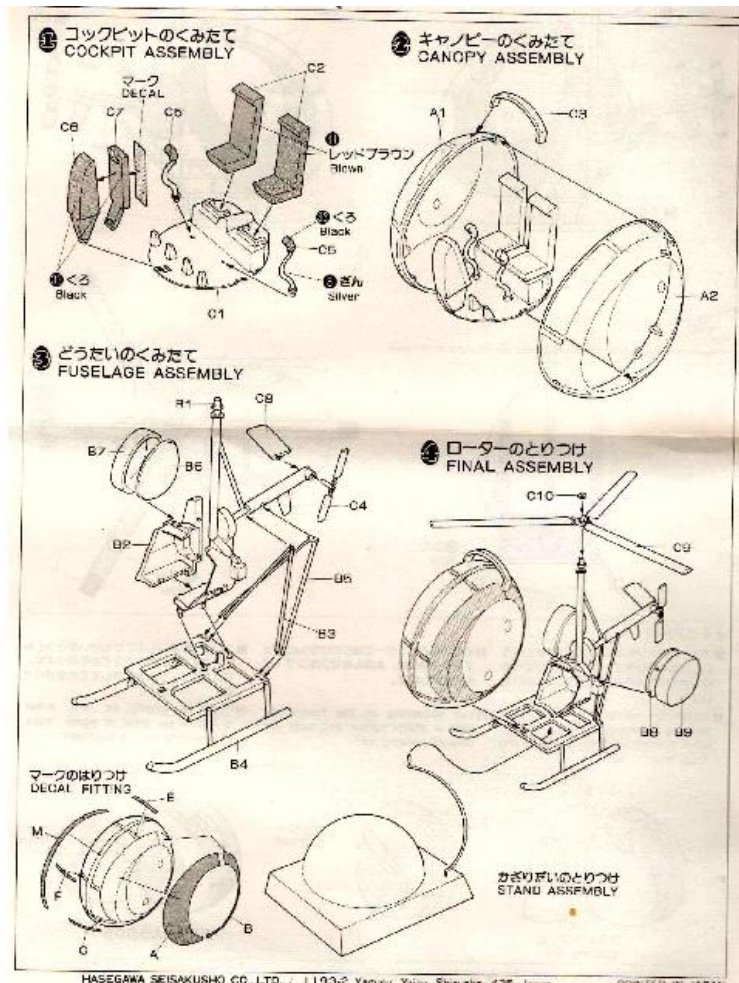

Not the exact instruction sheet, but an earlier iteration. Simple, no?
(Stand no longer included)

Decal Sheet



Finishing off the box's contents is a 2 5/8" by 5 1/4" decal sheet. There is no indication as to who produced the decals, but the decals appear to be properly in registration with no excess carrier film.

A nice added touch is the inclusion of "eye" decals and uniform patches for the figure.

When all is said and done, I think this will turn out to be a pleasant and relaxing build, including the figure.

The helicopter is basically an all-black affair. And Amy is in a dark blue policewoman's outfit.

Currently, Hobby Link Japan shows this kit as discontinued with the MSRP being shown as just over \$21.

Neither Amazon nor Hasegawa's home page show the Amy McDonnell/Hughes 300 kit being available.

Or any of the Egg Girl Collection for that fact. For the fun of it, I went to eBay and found 4 examples of the Amy McDonnell/Hughes 300 kit going for anywhere between \$37 and \$65 dollars. Oh well, another lost opportunity.

Just as a PS to this review, I have a total of 8 egg planes – 4 of which have not been built yet. Of the built kits, I have a Greek Phantom, a Cambodian MiG-15, a Japanese MV-22 Osprey and a Dutch PBX Catalina.

The unbuilt kits include a partially built SR-71, and unbuilt Grumman TBF/TBM, the Hughes Model 300 and a VF-15 Strike Valkyrie. I've got the Reskit cockpits for both the SR-71 and TBF/TBM, while both the Hughes 300 and VF-15 have resin figures. *-kent fini*

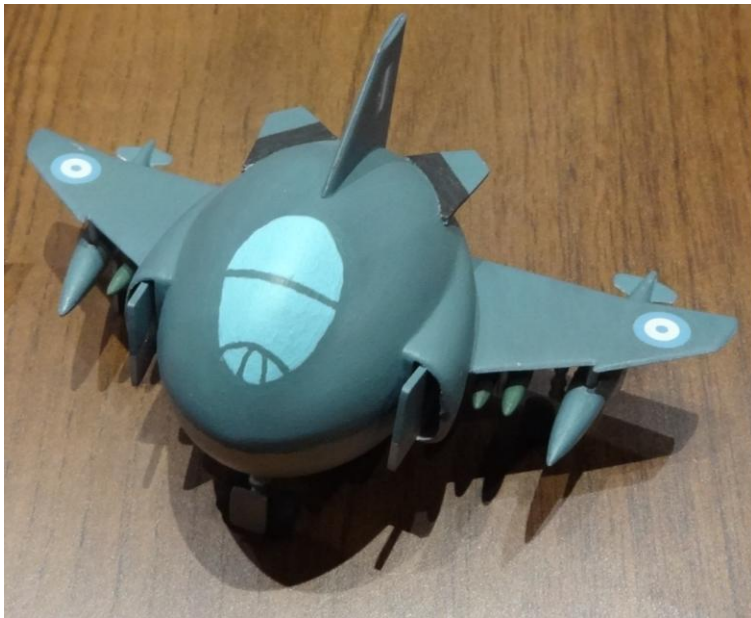

OCTOBER 2026 MEMBER's Club Contest

OCTOBER SKY !

It's All about MISSILES and ROCKETS, OH MY

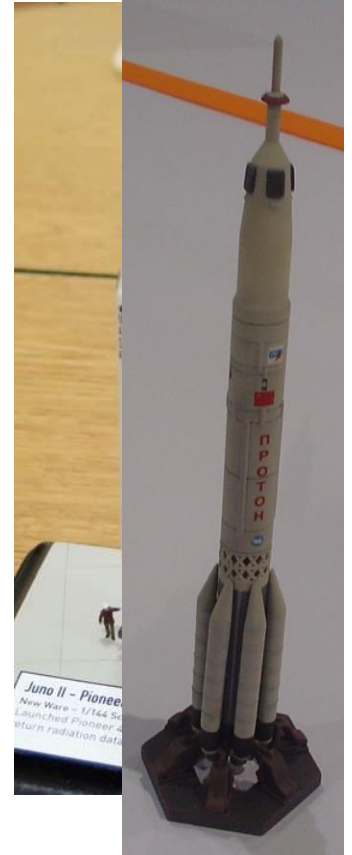
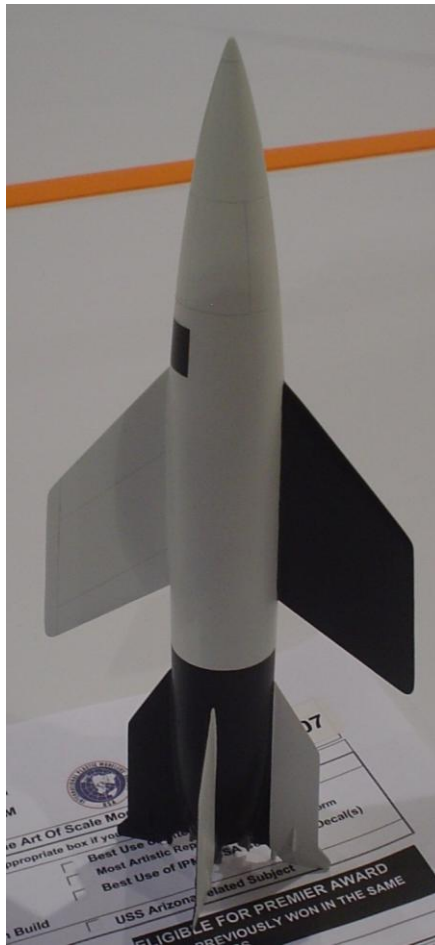

CASH PRIZES !

ALL SCALES & TYPES & MEDIA

Thank You Mark Balderrama for this gig !

YES, Your SPARROW, ATOLL, HVAR, SNARK, BOMARC & RHEINTOCHTER also may enter against these competitors

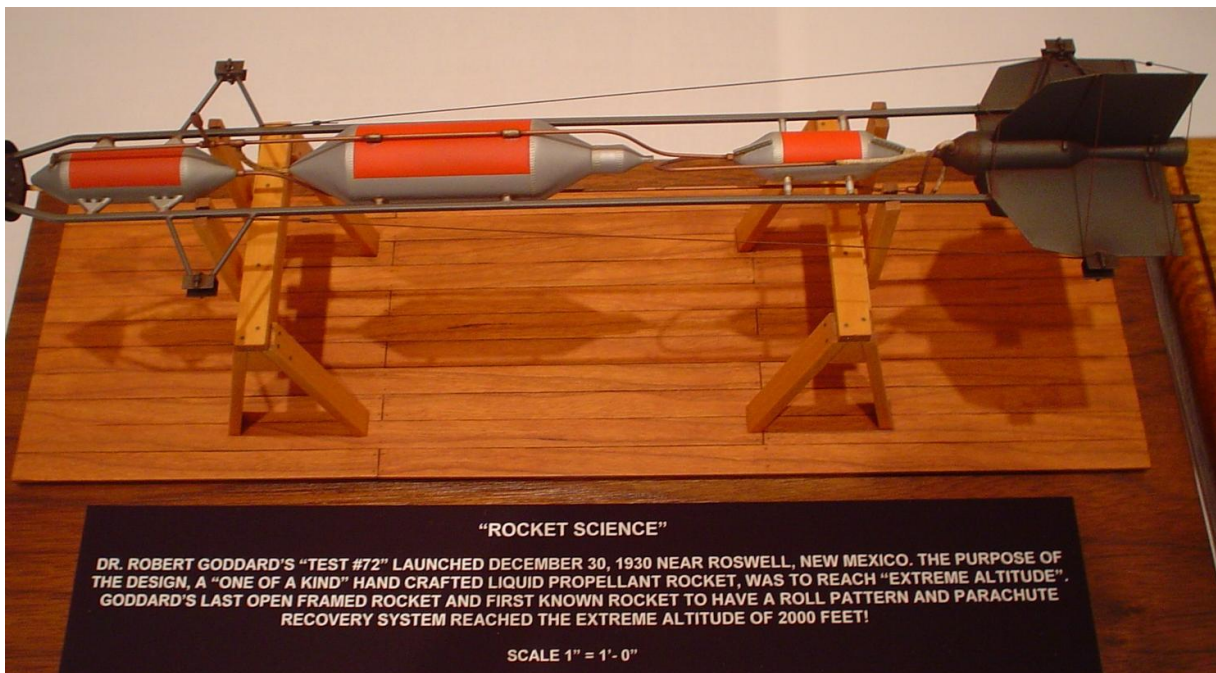

YES, WE HAVE AN AUGUST EVENT
To look ahead to as well...

A long time ago in a galaxy far, far away...

2026 Model Contest
Hosted By:

San Joaquin Valley Scale Modelers
(SJVSM)

The Tomcats

Theme: George Lucas Films

The SJVSM Model Contest is a
Non-IPMS (International Plastic Model Society)
Details visit: www.deltatomcats.com (scan below)

Date: August 29, 2026 (Saturday)

Location: Stanislaus County Veterans Services
3500 Coffee Road,
Suite 19
Modesto, CA



Model Show and Contest Fund Raiser for the Veterans Hall

Date: August 29, 2026 (Saturday)

Location: Stanislaus County Veterans Services
3500 Coffee Road, Suite 19
Modesto, CA

Contestant Admission Price:

Seniors: \$15.00 for unlimited number of models.
(18 and up)

Juniors: \$ 10.00 for unlimited number of models.
(14-17)

Sub-Junior: Free for any quantity of models.
(5-13)

Spectators: Free

Schedule:

7:00 AM: Doors open for vendor set up.

9:00 AM: Doors open for registration.

12:00 PM: Registration closes.

1:00 PM: Judges meeting.

1:15 PM: Judging begins.

3:30 PM: Awards

Amenities:

Free Parking: There is plenty of parking available.

Food: There may be in facility eating available but there is plenty of eating establishments within walking distance.

Raffles:

There will Be Two Raffles during the day which will include models and model related items. Times of raffles will be posted.

Raffle Tickets will be broken into two categories:

Regular: \$1.00 per ticket
\$20.00 per 25 tickets

Premium Tickets: \$5.00 per ticket

Vendors:

Each table will cost \$25.00

Contact: Tony Quartaro for tables & availability.

Phone: (209) 665-6599



Email: Thedeckguy53@gmail.com

San Joaquin Valley Scale Modelers History

The Club was started in 1983 as the "Stockton Tomcats" a Chartered Club of IPMS-USA. Over the years, we have held meetings at numerous places with several goals in mind; share modeling ideas; help other modelers and gather in a very none structured setting. We started at the Seifert Community Center in Stockton, CA where we held several local and regional model contests. Next we met at Modesto Hobby and Crafts for many years until Brad closed the store. Then we started meeting at Alan Weber's hanger at the Stockton Airport. Tony Quartaro joined the club and we started meeting at his house/garage in Manteca, CA. Now we hold meetings at both Tony's or Alan's depending on the circumstances. Many of our club members have entered and won awards and judged at many Local, Regional and National contests. Now we are known as the San Joaquin Valley Scale Modelers (SJVSM). Currently we are not a Chartered Chapter with IPMS-USA but many in our club are Members of IPMS-USA.



AND LITERALLY The Day After...

 **WONDERCON IV** 
August 30, 2026
9a.m. to 4p.m.
Scale Model Show and Swap Meet
Open Judging - Gold, Silver, Bronze
Multi-Category Model Contest

Oxnard Performing Arts Center
800 Hobson Way
Oxnard, CA

\$10 Admission & \$3 entry fee per model
3 entries per person per class maximum

Lots of Free parking at the Center
Swap Meet - limited 6', 8', & 12'
vendor tables available

WAR IN THE DESERT!
In honor of 35TH ANNIVERSARY OF DESERT STORM
modelers will have chance to show their skills in modeling
any and all wars that have been fought in the desert
over time.

FOR MORE INFO CONTACT
JC OSBORNE- JOSS1952@GMAIL.COM
LOU FRANCO - C130JLOU@YAHOO.COM
SCOTT EYLER- SJYLER4@VERIZON.NET-



THEN IN SEPTEMBER – OH YES !

25TH ANNUAL MODEL CONTEST

THEME

**Red,
White
& Blue**



Contest Celebrating 250 years
of American Independence

**2 BIG RAFFLES
SWAP MEET**

Date: Saturday - September 26, 2026

9:00AM - 4:00PM

National Automobile Museum

1 Museum Drive - Reno, Nevada

Admission Fee: \$10.00 Adults - Children 5 and Under - Free
Contest Entry \$6.00 for First Model - \$1.00 for Each Additional Model
Chapter Contact: - Douglas Summers (775) 867-8554 - ghpltd@att.net
Vendors Contact:- Andre Urruty for Reservations: urrutyam@gmail.com

Visit us at www.renohighrollers.com

**2 FREE
RAFFLE TICKETS
WITH ADMISSION**

Admission Includes
Full Access to
Museum Exhibits



Followed by TWO October delights !

First, on a So Cal Sunday



OrangeCon

IPMS USA Region 8 Model Contest
& Vendor Fair
and First-Time AMPS Regional Meet
October 11, 2026



Be a part of Southern California's
largest exhibit of scale models

Location: The Double Tree Inn by Hilton
7000 Beach Blvd
Buena Park, CA 90620
(Immediately off the 91 Freeway at Beach Blvd.)

Schedule:

Open to the Public	9:00 AM to 5:00 PM
Vendor Set-Up	7:00 AM to 9:00 AM
Vendor Room Open	9:00 AM to 2:30 PM
Model Registration	9:00 AM to 11:30 PM
Contest Judging*	Noon to 3:00 PM
Awards Presentation	3:30 PM to 5:00 PM

*Members of the Contest Team will be open during judging on a rotating basis.
Your cooperation is requested.

Admission:

Spectator Admission (No contest entries)	\$ 7.00
Contest Admission (Adult & Ages 13-17) (includes first 2 models)	\$10.00
Contestants Under Age 12	Free
Model entry fee after first 2 models	
Adults	\$ 1.00 each
Junior and Young Adult	Free

All categories will be awarded in 1st, 2nd, 3rd-place format and judged by IPMS rules. For a complete list of contest rules, registration forms and other information, please visit our website at: www.ipmsoc.org

For more information:
IPMS Orange County, P.O. Box 918, Garden Grove, CA 92642
web: www.ipmsoc.org * email: admin@ipmsoc.org

OrangeCon Theme:

**AMERICAN
SPIRIT!**

Celebrating 250 Years of Independence!

We're looking for the most gung-ho, star-spangled, eagle-soaring, freedom-ringing model on the table! And if it's Gundersen raising Old Glory on two jims, so be it, because all categories can get in on this action! Do you have enough American Spirit?

Special thanks to AMPS and SoCal AMPS for their co-sponsorship and judging support, and provision of medallion awards for the armor categories! All modelers are invited to participate in their non-contest open model display of the M213 family of vehicles!



Then on following So Cal Saturday...

Desert Classic XXVIII

Presented by

The Antelope Valley Group

IPMS Region 8

Saturday October 17th, 2026

Antelope Valley College Cafeteria
3041 W. Ave K, Lancaster CA 93536

This Year's Theme:
**"Feminine
Phenomenons"**



Categories

1. Rotary Wing, All Scales & Types
2. Aircraft; Biplanes, All Scales & Types
3. Aircraft 1/73 & Smaller
4. Aircraft 1/72 Prop
5. Aircraft 1/72 Multi Engine Prop
6. Aircraft 1/72 Jet
7. Aircraft 1/48 Prop
8. Aircraft 1/48 Multi Engine Prop
9. Aircraft 1/48 Jet
10. Aircraft 1/32 & Larger
11. Ships 1/500 & Larger
12. Ships 1/501 & Smaller
13. Submarines: All Scales & Types
14. Military Vehicles Small Scale 1/36 & Smaller All Types
15. Tanks/Assault Guns Closed Top -1945 & Earlier (1/35 & Larger)
16. Tanks/Assault Guns Closed Top 1946 & Later (1/35 & Larger)
17. Artillery & Open Top Self-Propelled Guns (1/35 & larger)
18. Military Vehicles Tracked (1/35 & Larger)
19. Military Vehicles Wheeled (1/35 & Larger)
20. Auto Factory & Replica Stock
21. Auto Street Machine & Hot Rods
22. Auto Cruisers, Customs, Low Riders
23. Auto Competition Straight & Oval Track
24. Auto: Motorcycles & Miscellaneous
25. Commercial & Construction Vehicles
26. Figures: Historical
27. Figures: Fantasy/Sci-fi/Wargame 53mm & smaller
28. Figures: Fantasy / Sci-fi Biologic Types
29. Dioramas: All Compositions
30. Vignettes
31. Gundam / Mechs / Robots
32. Sci-Fi & Real Spacecraft
33. Miscellaneous
34. Jurassic Plastic (OOB Rules) Instructions Required
35. Tom Daniel Creations
36. Juniors: 17 & Under

Special Awards

Best of Show
Theme Award: "Feminine Phenomenons"
Presidents Award
David Newman X-Plane Award
Best Auto Finish
Best Sci-Fi/Fantasy Subject
Best A-10
Best Lockheed P-38
Best Boeing B-17
Best NASA Subject
Best Reconnaissance Subject
Spirit of '76
Trophy Hound Award

Schedule:

Registration 9:00 AM to Noon
Judging 12:30 PM to 3:00 PM
Awards Presentation 3:00 PM to 4:00 PM

Fees:

Adult: \$15.00 up to 3 entries.
\$1.00 ea. per additional entry.
Juniors: FREE
Spectators: FREE
Vendors: \$45.00 Per table (reserved)
\$50.00 at the door.

Vendor Contact: Curtis Stidham

cbstidham@sbcglobal.net <http://www.avg-imps.org>

7:00 PM OPEN, MEETING ENDS 10:00 PM SHARP

3rd FRIDAY of Month

JUNE 19 (at TRADITIONAL meeting site)

COMMUNITY ROOM

Milpitas Police Administration Building

1275 N. Milpitas Blvd
Milpitas, CA

July 17 SVSM "Ride
The Wave"



Sponsored by Frank Beltran

FOR NOW - QUITE SIMPLY, ANY PERIOD or TYPE of SEAPLANE, FLOAT PLANE and not to diss them, CATAPULT LAUNCH AIRCRAFT (true catapult system as they can take off on their own if given the runway...) YES if you must, FLYING BOAT are equivalent to the qualifying parameters already outlined, got that?

CASH PRIZES and PLENTY TO CHOOSE FROM



PLEASE SHARE THE JOY OF OUR HOBBY AND FRIENDS

Because it seems sometimes more than a few forget this :

THE ONE TRUE RULE OF MODELLING (if ever there is).

*If you're having fun,
Then you're doing it right.*



EDITOR
SILICON VALLEY SCALE MODELERS
P.O. BOX 361644
MILPITAS CA 95036
Email : dens25403@mypacks.net

